

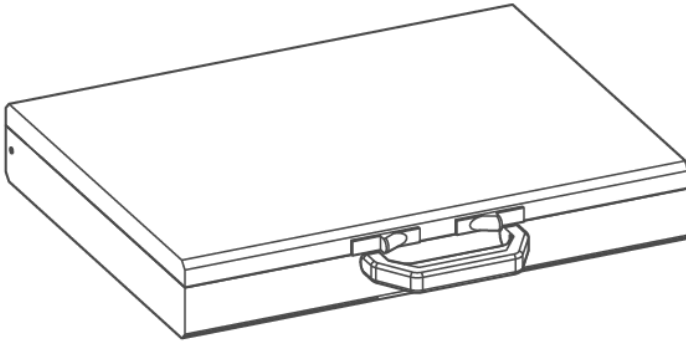

qr.gruenbeck.de/032

We understand water.



## Heating | Analysis case

Operation manual

grünbeck

**General Contact  
Germany**

**International Sales**

Phone +49 9074 41-145

**Technical Service**

Phone +49 9074 41-333

Fax +49 9074 41-120

**Availability**

Monday to Thursday

7:00 am - 6:00 pm

Friday

7:00 am - 4:00 pm

We reserve the right to technical modifications.  
© by Grünbeck AG

Original operation manual  
Edition: February 2025  
Order no.: 100067010000\_en\_045

# Table of contents

<b>Table of contents</b> .....	<b>3</b>	<b>4 Transport and storage</b> .....	<b>20</b>
<b>1 Introduction</b> .....	<b>4</b>	4.1 Transport .....	20
1.1 Validity of the manual .....	4	4.2 Storage .....	20
1.2 Target group .....	4		
1.3 Other applicable documents .....	5	<b>5 Maintenance and repair</b> .....	<b>21</b>
1.4 Product identification .....	6	5.1 Cleaning .....	21
1.5 Symbols used .....	6	5.2 Maintenance .....	21
1.6 Depiction of warnings .....	7	5.3 Consumables.....	22
		5.4 Spare parts .....	22
<b>2 Safety</b> .....	<b>9</b>	5.5 Wearing parts .....	22
2.1 Safety measures .....	9		
2.2 Product-specific safety instructions.....	11	<b>6 Disposal</b> .....	<b>23</b>
		6.1 Packaging .....	23
<b>3 Product description</b> .....	<b>12</b>	6.2 Dosing chemicals .....	23
3.1 Intended use .....	12	6.3 Product .....	23
3.2 Product components.....	12		
3.3 Functional description .....	16	<b>7 Technical specifications</b> .....	<b>24</b>
3.4 Accessories .....	19	<b>Notes</b> .....	<b>26</b>

# 1 Introduction

This manual is intended for qualified specialists in the heating trade. The manual is an integral part of the product.

- ▶ Carefully read this manual and the included manuals on the components before you operate your product.
- ▶ Obey all safety instructions and handling instructions.
- ▶ Keep this manual and all other applicable documents, so that they are available when needed.

## 1.1 Validity of the manual

This manual applies to the following products:

- Analysis case Heating
- Analysis case Steam boiler
- GENO-therm analysis case

## 1.2 Target group

Grünbeck's technical service/authorised service company or qualified specialists trained by Grünbeck.

- Expertise in the application of the product is assumed.

## 1.3 Other applicable documents

For the water test kits below, the respective manufacturer's operation manuals are enclosed.

You will find the operation manuals either included in the analysis case or in the respective packaging of the water test kit.

### **Analysis case Heating (170 192):**

- Water test kit Total hardness
- pH indicator strips pH 7 – 14
- Water test kit Ortho-phosphate
- Water test kit Sulphite

### **Analysis case Steam boiler (170 195):**

- Combined measuring device for pH and conductivity
- Water test kit Hardness determination (0 – 2 °dH)
- Water test kit Duroval type CPM
- Water test kit Ortho-phosphate
- Water test kit Sulphite

### **GENO-therm analysis case (707 190, 707 192):**

- Combined measuring device for pH and conductivity
- Water test kit Hardness determination (0 – 2 °dH)
- Water test kit Total hardness
- Water test kit Molybdenum



## 1.4 Product identification

You can identify your product based on the product designation and the order no. indicated on the type plate.

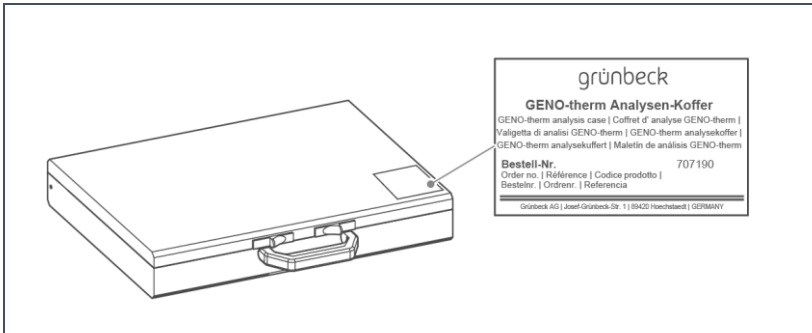
The type plate is located on the side of the analysis case.



## 1.5 Symbols used

Symbol	Meaning
	Danger and risk
	Important information or requirement
	Useful information or tip

## 1.6 Depiction of warnings



This manual contains information and instructions that you must obey for your personal safety. The information and instructions are highlighted by a warning symbol and have the structure below:



**SIGNAL WORD** Type and source of danger

- Possible consequences
- ▶ Preventive measures

The signal words below were defined subject to the degree of danger and might be used in the present document:

Warning symbol and signal word	Consequences if the information/instructions are ignored	
 <b>DANGER</b>		Death or serious injuries
 <b>WARNING</b>	Personal injuries	Possible death or serious injuries
 <b>CAUTION</b>		Possible moderate or minor injuries
<b>NOTE</b>	Damage to property	Possible damage to components, the product and/or its functions, or an object in its vicinity

## 1.6.1 Personal protective equipment

- ▶ As an owner/operating company, make sure that the required personal protective equipment is available.

The following components fall under the heading of personal protective equipment (PPE):



---

Protective gloves

---



---

Protective footwear

---



---

Protective goggles

---

## 2 Safety

### 2.1 Safety measures

- Obey the local regulations on drinking water protection, accident prevention and occupational safety.

#### 2.1.1 Danger due to chemicals



Current safety data sheets for chemicals are available for download at [www.gruenbeck.de/en/info-centre/safety-data-sheets](http://www.gruenbeck.de/en/info-centre/safety-data-sheets).

- ▶ Obey in-house instructions when handling chemicals. Make sure that protective and emergency equipment such as emergency showers and eyewash are available where required, and functional.

#### **Mixing and residual amounts of chemicals**

- Do not mix different chemicals. Unforeseeable chemical reactions with mortal danger can occur.
- Dispose of residual amounts of chemicals in accordance with local regulations and/or in-house instructions.
- Residual amounts from used containers should not be filled into containers with fresh chemicals in order not to impair the effectiveness of the chemicals.

#### **Labelling/Minimum shelf life/Storage of chemicals**

- Check the labelling of the chemicals. Chemical labels must not be removed or made illegible.
- Do not use any unknown chemicals.

- Comply with the use-by date (minimum shelf life) stated on the label.
- If stored incorrectly, chemicals could change their state of matter, crystallize, outgas, or lose their effectiveness. Store and use the chemicals at the given temperatures only.

### **Cleaning/Disposal**

- Immediately absorb spilled chemicals with suitable binding agents.
- Collect and dispose of chemicals in such a way that they cannot pose any risks to people, animals, or the environment.

## 2.1.2 Groups of persons in need of protection

- Children must not play with the product.
- This product is not designed to be used by persons (including children) with reduced capabilities, lack of experience or knowledge.

## 2.2 Product-specific safety instructions

The analysis case contains chemicals that – if applied incorrectly – can be hazardous to the health and safety of the user or to the environment.



### CAUTION

Chemicals are hazardous to health and environment.

- They can cause skin and eye burns as well as irritation of the respiratory tract or allergic reactions.
- ▶ Avoid any skin/eye contact with chemicals.
- ▶ Use personal protective equipment.
- ▶ Read the safety data sheet before handling chemicals. Obey the instructions for different activities/situations.
  
- ▶ Do not eat, drink or smoke while working with the analysis case.
  
- ▶ Properly rinse your equipment after each analysis in order to avoid carry-over errors.
  
- ▶ Never pour reagent samples back into the supply bottles, so as to avoid contamination.

## **3 Product description**

### **3.1 Intended use**

The analysis case is designed for the proper determination of heating water or boiler water parameters.

The analysis case is for exclusive use in industrial and commercial applications only.

### **3.2 Product components**

- ▶ Check the scope of supply for completeness and damage.

### 3.2.1 Scope of supply of analysis case Heating (170 192)

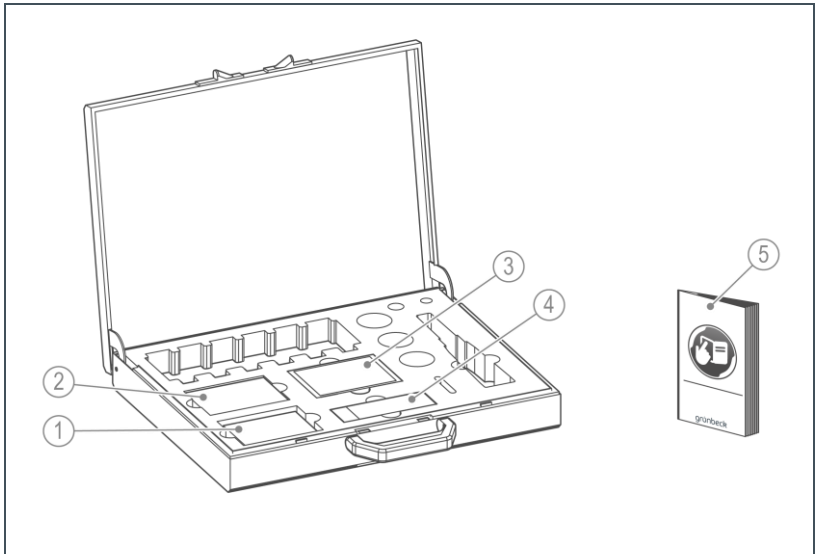

#### Designation

- 1 pH indicator strips pH 7 – 14
- 2 Water test kit Total hardness
- 3 Water test kit Ortho-phosphate

#### Designation

- 4 Water test kit Sulphite
- 5 Operation manual

### 3.2.2 Scope of supply of analysis case Steam boiler (170 195)

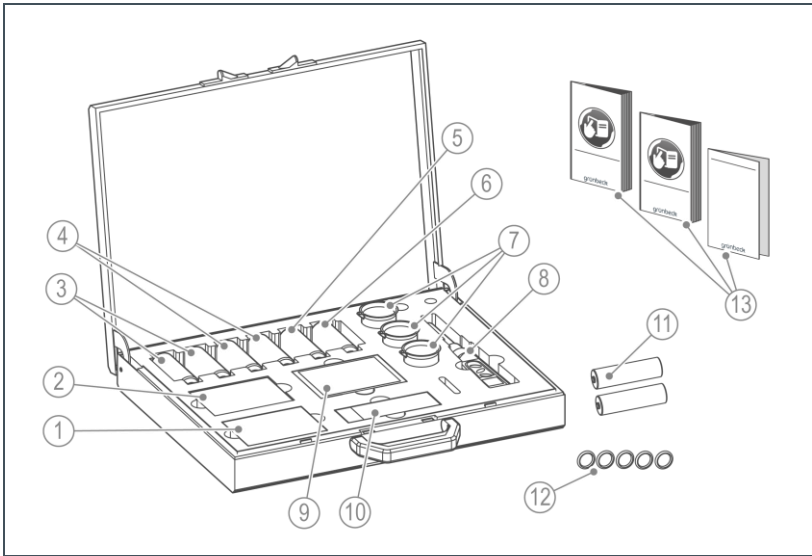

Designation	
1	Water test kit Total hardness
2	Water test kit Hardness determination (0 – 2 °dH)
3	Calibration solutions pH 4 (2x)
4	Calibration solutions pH 7 (2x)
5	Calibration solution Conductivity 1413 µS/cm
6	Potassium chloride solution KCL
7	Griffin beakers VIT-LAB, 50 ml, PP (3x)

Designation	
8	Combined measuring device for pH and conductivity
9	Water test kit Ortho-phosphate
10	Water test kit Sulphite
11	Batteries for the combined measuring device (2x)
12	O-rings (5x)
13	Operation manuals

### 3.2.3 Scope of supply of GENO-therm analysis case (707 190, 707 192)

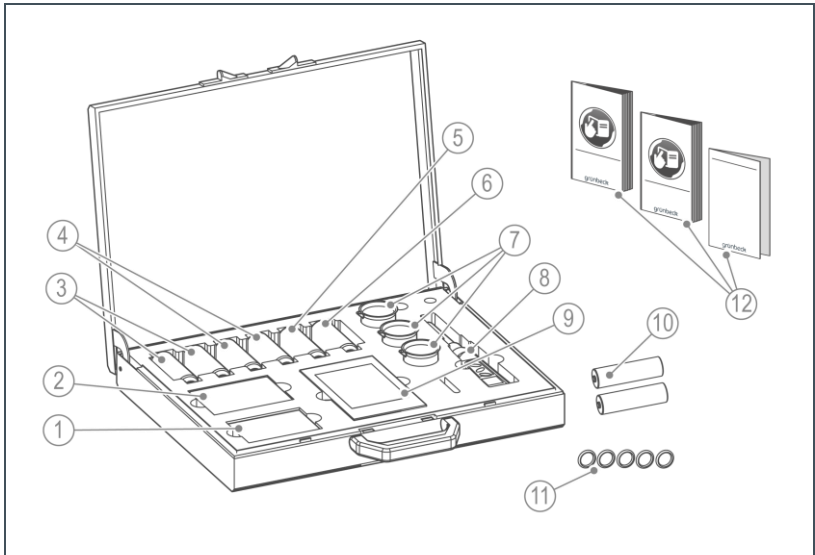

Designation	
1	Water test kit Total hardness
2	Water test kit Hardness determination (0 – 2 °dH)
3	Calibration solutions pH 4 (2x)
4	Calibration solutions pH 7 (2x)
5	Calibration solution Conductivity 1413 µS/cm
6	Potassium chloride solution KCL

Designation	
7	Griffin beakers VIT-LAB, 50 ml, PP (3x)
8	Combined measuring device for pH and conductivity
9	Water test kit Molybdenum (not included in analysis case 707 192)
10	Batteries for the combined measuring device (2x)
11	O-rings (5x)
12	Operation manuals

### 3.3 Functional description

#### 3.3.1 Requirements

According to VDI 2035-1 and -2 as well as DIN EN 14868, heating water has to meet certain water parameters, so as not to have a corrosive effect or not to promote furring. Furring has an adverse effect on the efficiency of the heating system. Corrosion may attack the entire heating system, which can require the replacement of individual or several parts of the system.

#### 3.3.2 Combined measuring device for pH and conductivity

By means of the combined measuring device, the pH value and the conductivity (temperature-compensated up to 60 °C) can be measured. To ensure correct measurements at all times, the device should be calibrated before use. The calibration solutions required to do so are included in the analysis case.

##### **pH value**

To prevent the risk of corrosion, the pH value must be measured 8 – 12 weeks after the heating system has been filled for the first time and then once a year. If additives are added to the heating water in order to prevent furring or corrosion, their concentration must be measured every year as well.

The pH value is defined as a negative, ten-base logarithm of the hydrogen ion concentration. The more acid a solution is, the lower its pH value. pH 7 indicates a neutral solution, whereas higher pH values indicate alkaline conditions.

acid	neutral	alkaline
0	7	14

## pH value acc. to VDI 2035 for heating systems

pH value at 25 °C	
8.2 – 10.0	
8.2 – 8.5	for components made of aluminium or aluminium alloys
8.2 – 9.0	for components made of selected aluminium alloys according to the manufacturer's information

## Conductivity

Conductivity (LF or COND) refers to the total of all minerals dissolved in the water. Water conducts electricity all the better, the more minerals it contains. By measuring the electrical conductivity, the ions of these dissolved minerals can be detected. They are given in the unit of measurement  $\mu\text{S}/\text{cm}$ .



If a system has been filled with fully demineralised water and then additives (e.g. thermalIQ safe, GENO-phos no. 1, GNEO-safe A) are mixed in, the conductivity increases.

### 3.3.3 Total hardness

Total hardness refers to the total of all alkaline earth ions (mainly calcium and magnesium) dissolved in the water. The hardness is measured in German degrees of hardness ( $^{\circ}\text{dH}$ ) or  $\text{mmol}/\text{l}$ . The more hardness is contained in the heating water, the more deposits can be formed.

### 3.3.4 Phosphate

Products containing phosphates (e.g. GENO-phos no. 1) are added to the boiler and the heating water in order to precipitate the residual hardness and to increase the pH value. The phosphate concentration can be monitored with the water test kit for ortho-phosphate.

### 3.3.5 Sulphite

Sulphite is added to the boiler and the heating water to bind traces of surplus oxygen. The required sulphite surplus can be monitored with the water test kit for sulphite.

### 3.3.6 Molybdenum



Molybdenum is a metal of the chromium group. In GENO-safe A , molybdenum is present as molybdate, which can combine with surfaces (made of steel, copper and aluminium) to form a protective layer. This protective layer acts as a protection against corrosion. The molybdenum concentration in the heating water should be checked once a year. If the value is too low, corrosion may occur.



The pH value, the conductivity, the total hardness, the phosphate and the sulphite concentration as well as the molybdenum concentration can be measured in any water. If suspended particles are contained in the water, the sample must be filtered with suitable filter paper before the measurement.

### 3.4 Accessories

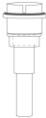
Your product can be retrofitted with accessories. Please contact your local Grünbeck representative or Grünbeck's headquarters in Hochstaedt/Germany for details.

Illustration	Product	Order no.
	<b>Spare electrode</b> for the combined measuring device	<b>100066020001</b>
	<b>Griffin beaker VIT-LAB, 50 ml, PP</b> as measuring beakers	<b>888 02 315</b>
	<b>O-ring 9.00 x 1.50 mm (EPDM 70 KTW, W270)</b> to seal the sensor cap of the combined measuring device	<b>870 03 021</b>
	<b>Carbon filter paper</b> 100 pieces of round filters type 508, 110 mm	<b>888 09 011</b>
	<b>PE funnel</b> As all-purpose funnel, transparent	<b>888 06 006</b>

## 4 Transport and storage

### 4.1 Transport

- ▶ Only transport the included water test kits in the analysis case.
- ▶ Keep all the components inside the analysis case when they are not in use.

### 4.2 Storage

- ▶ Protect the product from the impacts below when storing it:
  - Dampness, moisture
  - Environmental impacts such as wind, rain, snow, etc.
  - Frost, direct sunlight, severe heat exposure
  - Chemicals, dyes, solvents, and their vapours

## 5 Maintenance and repair

- ▶ Only use genuine spare and wearing parts from Grünbeck.

### 5.1 Cleaning

**NOTE:**

Do not clean the product with cleaning agents containing alcohol/solvents.

- These substances damage the plastic components.
- ▶ Use a mild/pH-neutral soap solution.
  
- ▶ Only clean the outside of the product.
  
- ▶ Do not use any strong or abrasive cleaning agents.
  
- ▶ Wipe the surfaces with a damp cloth.

### 5.2 Maintenance

Some regular work is necessary to ensure the proper functioning of the combined measuring device for pH and conductivity in the long term.



Obey the operation manual of the combined measuring device.

## 5.3 Consumables

Product	Order no.
Water test kit Hardness determination (0 – 2 °dH)	170 149
Water test kit Total hardness °dH and °f	170 187
Water test kit to determine the p and m value; Duroval type CPM	170 540
Water test kit Ortho-phosphate	170 554
Water test kit Sulphite	170 535
Water test kit Molybdenum	170 140
Calibration solution Conductivity 1413 µS/cm	203 624
Calibration solution pH 4	203 627
Calibration solution pH 7	203 628
Potassium chloride solution KCL	203 631

## 5.4 Spare parts

For an overview on the spare parts, see our spare parts catalogue at [www.gruenbeck.com](http://www.gruenbeck.com). You can obtain the spare parts from your local Grünbeck representative.

## 5.5 Wearing parts

Wearing parts are given below:

- Electrode for the combined measuring device
- Batteries for the combined measuring device

## 6 Disposal

- ▶ Obey the applicable national regulations.

### 6.1 Packaging

- ▶ Dispose of the packaging in an environmentally sound manner.

### 6.2 Dosing chemicals

- ▶ Obey the safety data sheets of the chemicals.

### 6.3 Product



If this symbol (crossed-out wheellie bin) is on the product, this product or its electrical and electronic components must not be disposed of as household waste.

- ▶ Dispose of electrical and electronic products or components in an environmentally sound manner.
- ▶ If your product contains batteries or rechargeable batteries, dispose of them separately from your product.



For more information on take-back and disposal, go to [www.gruenbeck.com](http://www.gruenbeck.com).

# 7 Technical specifications

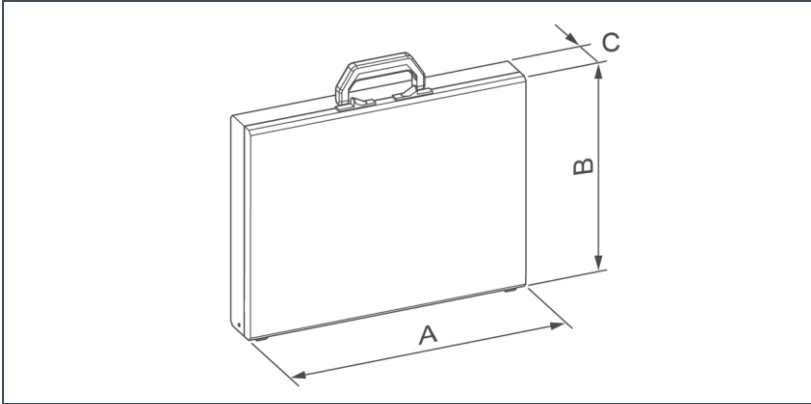

Dimensions and weights			Analysis case Heating	Analysis case Steam boiler	GENO-therm analysis case	
A	Width	mm	440			
B	Height	mm	330			
C	Depth	mm	66			
Shipping weight, approx			3.5	4.3	4.2	4.2
<b>Order no.</b>			<b>170 192</b>	<b>170 195</b>	<b>707 190</b>	<b>707 192</b>

# Notes

# Notes



Grünbeck AG  
Josef-Grünbeck-Str. 1  
89420 Hoechstädt/Germany



+49 9074 41-0



+49 9074 41-100

[info@gruenbeck.com](mailto:info@gruenbeck.com)  
[www.gruenbeck.com](http://www.gruenbeck.com)



For more information go to  
[www.gruenbeck.com](http://www.gruenbeck.com)