

We understand water.

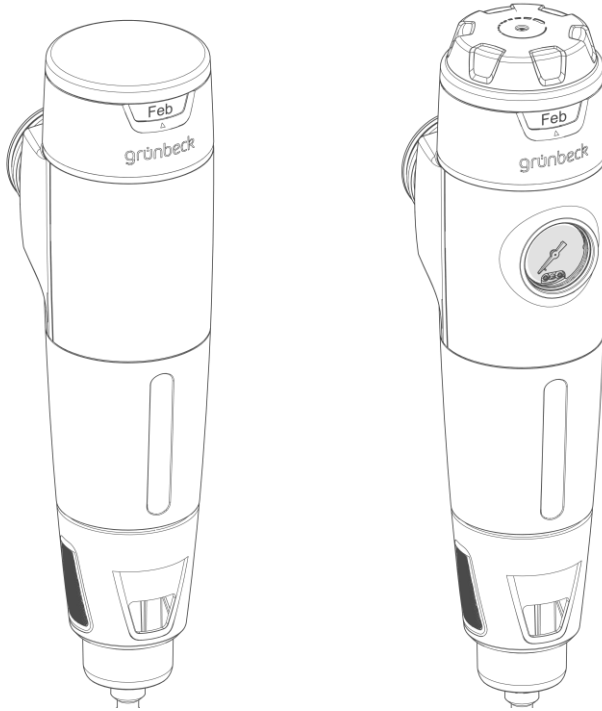

 cliQlock

Backwash filter | pureliQ:RX, pureliQ:RDX

Operation manual

grünbeck

Central Contact
Germany

Sales

 +49 (0)9074 41-0

Service

 +49 (0)9074 41-333
service@gruenbeck.de

Availability

Monday to Thursday
7:00 am - 6:00 pm

Friday
7:00 am – 4:00 pm

Subject to technical modifications.
© by Grünbeck AG

Original operation manual
Edition: August 2025
Order no.: 100263049900_en_025

Table of contents

1	Introduction	4	6.1	Checking the product.....	28
1.1	Validity of the manual.....	5	6.2	Setting the month display	29
1.2	Other applicable documents.....	5	6.3	Setting the pressure reducer (pureliQ:RDX).....	30
1.3	Product identification.....	6	6.4	Handing over the product to the owner/operating company	31
1.4	Symbols used	7			
1.5	Depiction of warnings.....	7			
1.6	Requirements for personnel	8			
2	Safety	10	7	Operation/handling	32
2.1	Safety measures	10	7.1	Installing Grünbeck's myProduct app.....	32
2.2	Product-specific safety instructions	11			
2.3	Conduct in emergencies	11	8	Maintenance and repair	33
3	Product description	12	8.1	Cleaning.....	33
3.1	Intended use.....	12	8.2	Intervals	34
3.2	Product components	13	8.3	Inspection.....	35
3.3	Functional description	14	8.4	Maintenance.....	36
			8.5	Spare parts	45
			8.6	Wearing parts.....	45
			8.7	Service Kits	46
4	Transport and storage	15	9	Fault	49
4.1	Transport	15	9.1	Observations	49
4.2	Storage.....	15			
5	Installation	16	10	Decommissioning	51
5.1	Requirements for the installation site.....	19	10.1	Temporary standstill	51
5.2	Checking the scope of supply.....	21			
5.3	Water installation	22	11	Dismantling and disposal	52
5.4	Attaching the backwash connection	23	11.1	Dismantling	52
			11.2	Disposal	54
6	Commissioning	28			

1 Introduction

This manual is intended for owners/operators/operating companies and qualified specialists and ensures the safe and efficient handling of the product. The manual is an integral part of the product.

- Carefully read this manual and the component instructions contained therein before you operate your product.
- Comply with all safety information and handling instructions.
- Keep this manual and all other applicable documents, so that they are available when needed.

Figures in this manual are for basic understanding and may differ from the actual version.

Retrieving information about the product

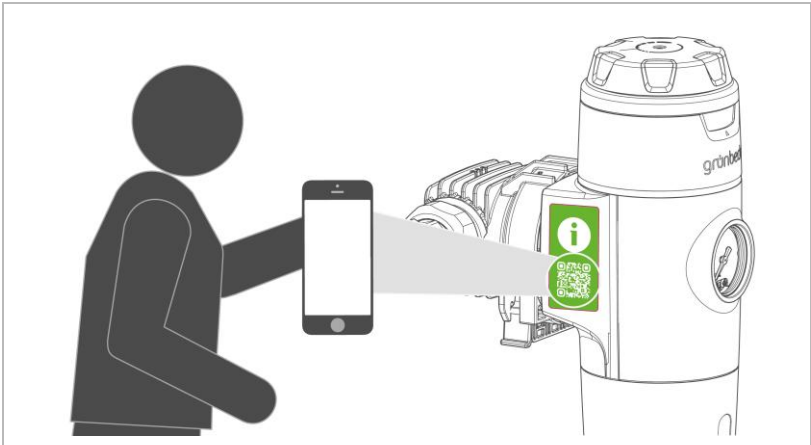

- ▶ Scan the QR code on the side of the product.
- » You will be redirected to the product page and can retrieve further information in the download area.

1.1 Validity of the manual

This manual applies to following products:

- Backwash filter pureliQ:RX
(Order no. 101000030000)
- Backwash filter pureliQ:RDX
(Order no. 101000040000)

1.2 Other applicable documents



In the interests of sustainability, we provide the product data sheet, checklists and these instructions on our homepage for you to download.

- Mounting instructions for the cliQlock basic module
- Mounting instructions for the cliQlock module system
- Product data sheet for the respective backwash filter
- Operation log with commissioning log and maintenance log



You have the following options for accessing the applicable documents:

- Scan this QR code
- Use this link: gr.gruenbeck.de/044

1.3 Product identification

You can identify your product by means of the product designation and the order number on the type plate.

- ▶ Check whether the products indicated in chapter 1.1 correspond to your product.



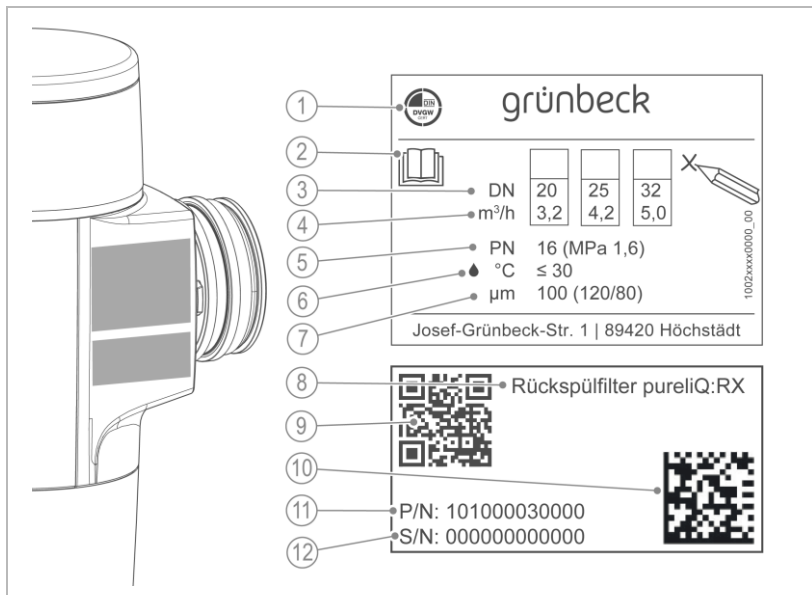





The type plate is located on the side of the filter.



Designation	
1	DVGW test mark
2	Obey the operation manual
3	Nominal connection diameter
4	Flow rate
5	Nominal pressure
6	Media temperature

Designation	
7	Pore size
8	Product designation
9	QR Code for the operation manual
10	Data matrix code
11	Order no.
12	Serial no.

1.4 Symbols used

Symbol	Meaning
	Danger and risk
	Important information or prerequisite
	Useful information or tip
	Written documentation required
	Reference to further documents
	Work that may only be carried out by qualified specialists
	Work that may only be carried out by qualified electricians
	Work that may only be carried out by technical service personnel

1.5 Depiction of warnings

This manual contains information and instructions that you must observe for your personal safety. The information and instructions are highlighted by a warning symbol and are structured as shown below:





SIGNAL WORD

Type and source of the hazard

- Possible consequences
- ▶ Preventive measures

The following signal words are defined depending on the degree of danger and might be used in this document:

Warning symbol and signal word	Consequences if the information/instructions are ignored	
 DANGER		Death or serious injuries
 WARNING	Personal injury	Possible death or serious injuries
 CAUTION		Possible moderate or minor injuries
NOTE	Damage to property	Possible damage to components, the product and/or its functions, or anything in its vicinity

1.6 Requirements for personnel

During the individual life cycle phases of the product, different people carry out work on the product. The work requires different qualifications.

1.6.1 Qualification of personnel

Personnel	Prerequisites
User	<ul style="list-style-type: none"> • No special expertise required • Knowledge of the tasks assigned • Knowledge of possible dangers in case of inappropriate behaviour • Knowledge of the necessary protection devices and protective measures • Knowledge of residual risks
Owner/operator/operating company	<ul style="list-style-type: none"> • Product-specific expertise • Knowledge of statutory regulations on work safety and accident prevention
Qualified specialist <ul style="list-style-type: none"> • Electrical engineering • Sanitary engineering (HVAC) • Transport 	<ul style="list-style-type: none"> • Professional training • Knowledge of relevant standards and regulations • Knowledge of detection and prevention of potential hazards • Knowledge of statutory regulations on accident prevention

Personnel	Prerequisites
Technical service (Grünbeck's technical service/authorised service company)	<ul style="list-style-type: none"> • Extended product-specific expertise • Trained by Grünbeck

1.6.2 Authorisations of personnel

The following table describes which activities are allowed to be performed by whom.

	User	Owner/ operator/ operating company	Qualified specialist	Technical service
Transport and storage		X	X	X
Installation and mounting			X	X
Commissioning			X	X
Operation and handling	X	X	X	X
Cleaning	X	X	X	X
Inspection	X	X	X	X
Maintenance	semi-annually	X	X	X
	Annually		X	X
Troubleshooting		X	X	X
Repair			X	X
Decommissioning and re-commissioning			X	X
Dismantling and disposal			X	X

1.6.3 Personal protective equipment

You do not need any protective equipment to operate the product.

2 Safety

2.1 Safety measures

- Only operate your product if all components are installed properly.
- Obey the local regulations on drinking water protection, accident prevention and occupational safety.
- Do not make any changes, alterations or extensions on your product.
- Only use genuine spare parts for maintenance or repair.
- Keep the premises locked to prevent unauthorised access and to protect endangered or untrained persons from residual risks.
- Comply with the maintenance intervals (refer to chapter 8.2). Failure to comply can result in the microbiological contamination of your drinking water system.
- Be aware of a possible risk of slipping due to leaking water on the floor.

2.1.1 Pressure-related hazards

- Components can be under pressure. There is a risk of injuries and damage to property due to escaping water and unexpected movement of components. Check the pressure lines and the product for leaks at regular intervals.
- Before starting repair and maintenance work, make sure that all affected components are depressurised.

2.1.2 Group of persons requiring protection

- Children must not play with the product.
- This product is not designed to be used by persons (including children) with reduced capabilities, lack of experience or lack of knowledge. Unless they are supervised, have been instructed on the safe use of the product and understand the resulting hazards.
- Cleaning and maintenance must not be carried out by children.

2.2 Product-specific safety instructions



WARNING

Excessive contamination of the filter element

- Risk of infection due to contamination
- ▶ Comply with the intervals and recommendations for inspection and maintenance of the filter.
- ▶ Do not unlock the cliQlock module system under pressure. Ensure that the water supply is shut off before unlocking the cliQlock modular system.

2.3 Conduct in emergencies

2.3.1 In case of water leaks

1. Close the shut-off valves for the water flow upstream and downstream of the product.
2. Locate the leak.
3. Eliminate the cause of the water leak.

3 Product description

3.1 Intended use

- The backwash filters pureliQ:RX and pureliQ:RDX are designed for the filtration of drinking water.
- The filters are designed according to the stipulations of DIN EN 13443-1 and DIN 19628 and are intended for installation into the drinking water system according to DIN EN 806-2 (installation immediately downstream of the water meter).
- The filters with pressure reducer are suitable for the adjustment of the downstream pressure on the withdrawal side in order to maintain the max. admissible operating pressure.
- They protect the water pipes and connected water-carrying system parts from disturbances and corrosion damage due to undissolved impurities (particles) such as rust particles, sand, etc.

Intended use

- The filters can be used for positive and negative pressure applications. The backwash, and adjustment of the downstream pressure on the withdrawal side, only works when applied in the positive pressure range.
- The filters can only be used in combination with the cliQlock module system.

3.1.1 Foreseeable misuse

- The filters are not suitable for circulation water that is treated with chemicals.
- The filters are neither suitable for oils, greases, solvents, soaps and other lubricating media, nor for the separation of water-soluble substances.

3.2 Product components

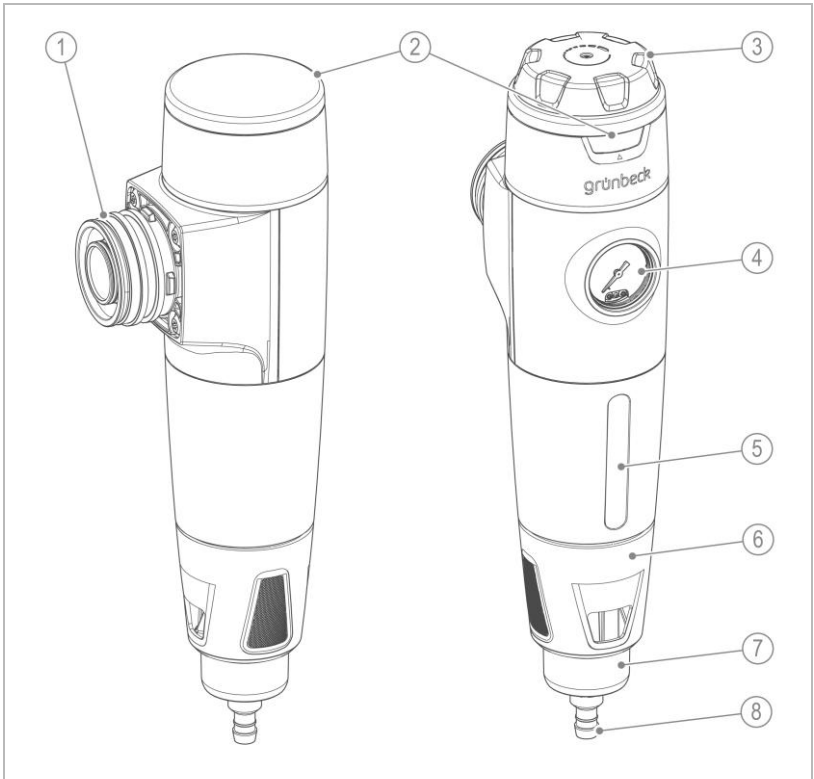

Designation

- | | |
|---|--|
| 1 | Slip-on coupling for cliQlock basic module |
| 2 | Maintenance ring with month indicator |
| 3 | Pressure reducer handwheel |
| 4 | Pressure gauge |

Designation

- | | |
|---|------------------------------|
| 5 | Inspection window |
| 6 | Backwash handwheel |
| 7 | Adapter for drain connection |
| 8 | Hose adapter |

3.3 Functional description

The unfiltered drinking water flows into the filter through the inlet side and from the outside in through the filter element and to the pure water outlet. Thus, foreign particles of a size $> 100 \mu\text{m}$ are retained.

Depending on their size and weight, foreign particles stick to the filter element or they fall straight down into the filter cylinder.

By turning the backwash handwheel to the stop position, the drain is opened. The water flows through the primary screen to the filter element and then flows through the filter element in the reverse direction to normal filtration. Particles sticking to the filter element are detached and washed out to the drain.

With the pureliQ:RDX backwash filter, the holding pressure on the withdrawal side can also be set to 1 - 6 bar using the pressure reducer (in accordance with DIN EN 1567).

4 Transport and storage

4.1 Transport

- ▶ Transport the product in its original packaging only.
- ▶ Obey the symbols and instructions on the packaging.

4.2 Storage

- ▶ Store the product protected from the following effects:
 - Dampness, moisture
 - Environmental impacts such as wind, rain, snow, etc.
 - Frost, direct sunlight, severe heat exposure
 - Chemicals, dyes, solvents and their vapours

5 Installation



The installation of the product represents a major intervention into the drinking water system and must be carried out by a qualified specialist only.

In accordance with DIN EN 806-2 and DIN EN 1717, the product is installed in the cold water pipe downstream of the water meter and upstream of distribution pipes and the appliances to be protected.

Installation example in horizontal pipe

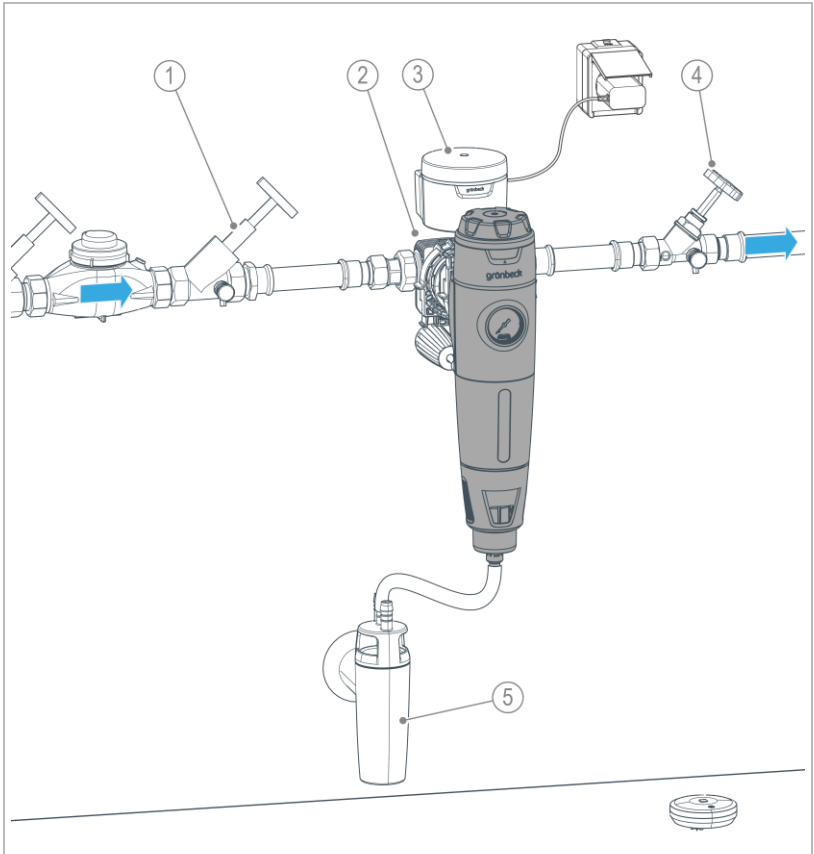

Designation

- 1 Inlet shut-off valve
- 2 cliQlock basic module
- 3 Leakage protection protectliQ:B

Designation

- 4 Outlet shut-off valve
- 5 Drain connection DN 50 acc. to DIN EN 1717

Installation example in vertical pipe

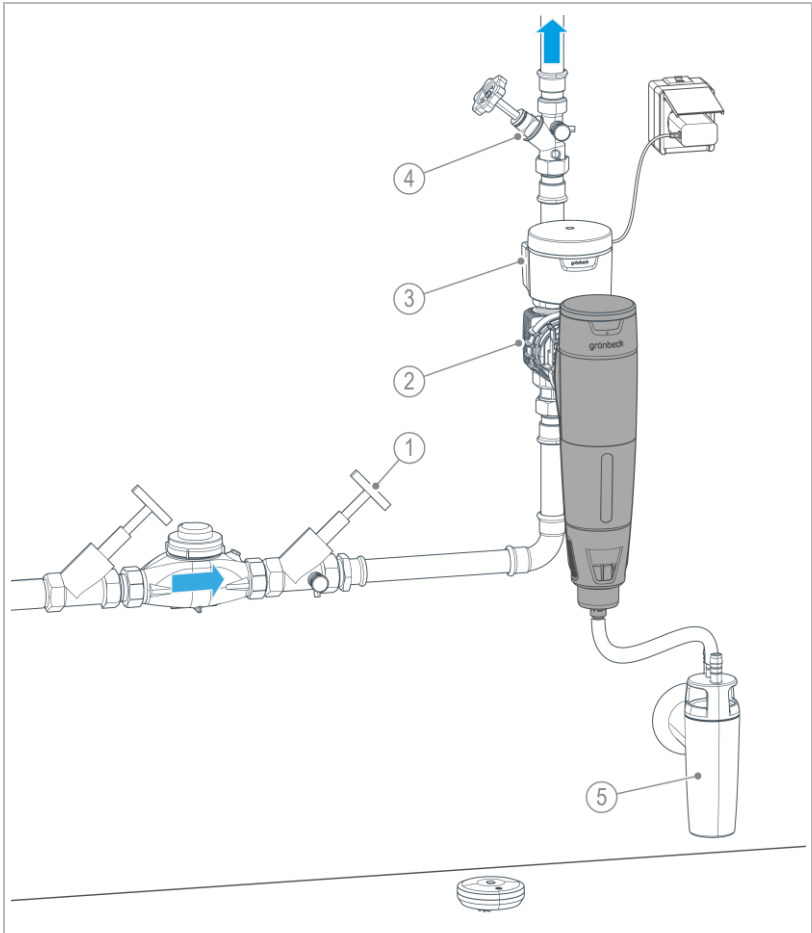

Designation

- 1 Inlet shut-off valve
- 2 cliQlock basic module
- 3 Leakage protection protectliQ:B

Designation

- 4 Outlet shut-off valve
- 5 Drain connection DN 50 acc. to DIN EN 1717

5.1 Requirements for the installation site

Obey the local installation directives, general guidelines and technical specifications.

- Protection from frost, severe heat exposure and direct sunlight
- Protection from chemicals, dyes, solvents and their vapours
- Ambient temperature and radiation temperature in the immediate vicinity
 - $\leq 25\text{ °C}$ for applications in the drinking water sector
 - $\leq 40\text{ °C}$ for purely technical applications
- Protection from heat sources (e.g. heating systems, boilers and hot water pipes)
- Access for maintenance work (take required space into consideration)
- Sufficiently illuminated as well as aerated and ventilated
- Pipe with sufficient load-bearing capacity to support the operating weight of the product

Space required

- There must be a clearance of at least 500 mm in front of the product for operation.

Water installation

- Floor drain or corresponding safety device with water stop function (e.g. leak protection protectliQ:B)
- Shut-off valves upstream and downstream of the product

5.2 Checking the scope of supply



Depending on your order, you will receive the backwash filter pureliQ:RX or the pureliQ:RDX backwash filter with pressure reducer.

The cliQlock basic module is not included in the scope of delivery.

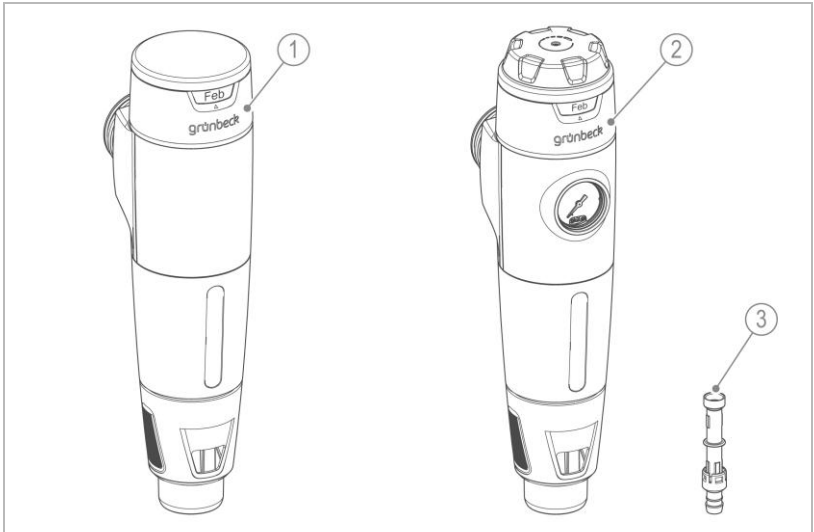

Designation	Designation
1 Backwash filter pureliQ:RX	3 Hose adapter
2 Backwash filter pureliQ:RDX	

- ▶ Check the scope of supply for completeness and damage.



The transparent plastic film serves as transport and dirt protection.

- ▶ Leave it on the product during assembly and the construction phase to prevent soiling of the white housing.

5.3 Water installation



The cliQlock basic module must already be installed.
The filter can be mounted in a horizontal or vertical pipe.



Install the cliQlock basic module and the filters in accordance with the mounting instructions for the cliQlock module system.

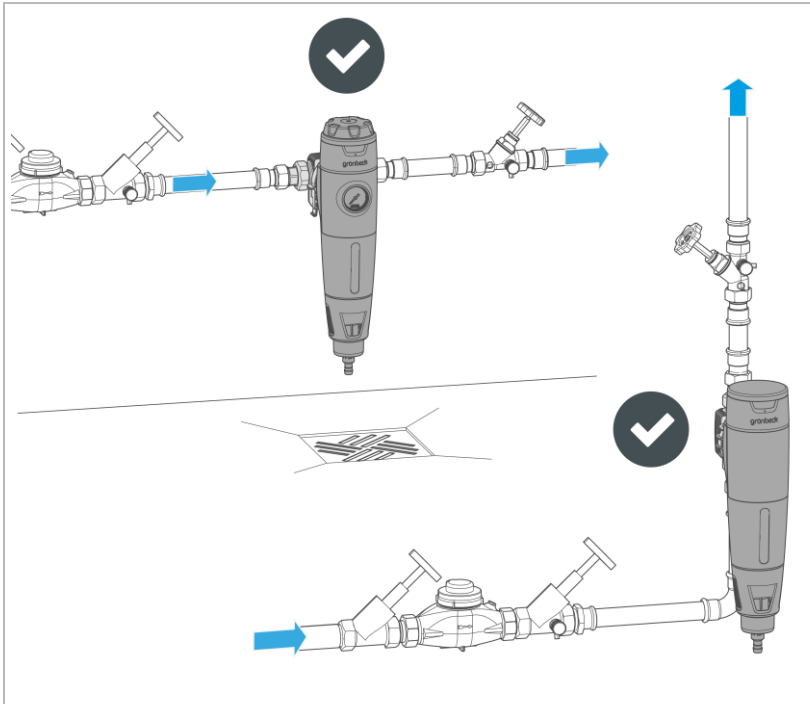

When removing the filter, the plug-in coupling can get stuck in the cliQlock basic module.

- ▶ When removing the filter, pay attention to the plug coupling in the cliQlock basic module (refer to chapter 11.1)

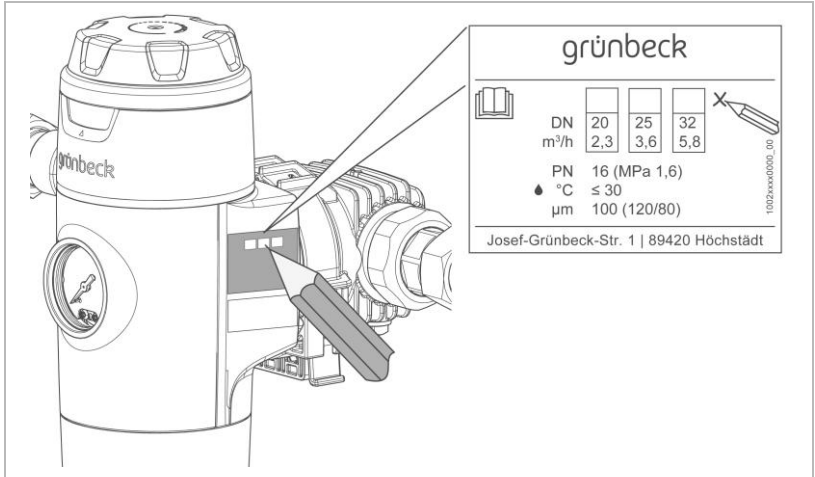

- ▶ Note the nominal connection diameter (DN) of the cliQlock basic module on the type plate.

5.4 Attaching the backwash connection



If it is not possible to install a waste water pipe, the backwash water can be collected in a bucket/container.

5.4.1 Backwash water discharge with drain connection

The supplied hose adapter is not required for this variant. The free outlet is already integrated in the filter for this variant.

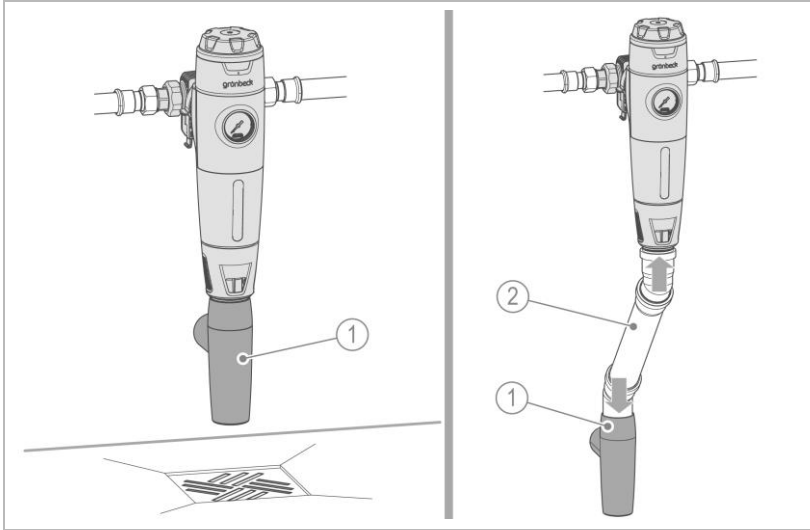

Designation

- 1 Drain connection DN 50 acc. to DIN EN 1717

Designation

- 2 Waste water pipe on site



Refer to the installation instructions for the drain connection.

- ▶ Install the drain connection (not included in the scope of supply).
- ▶ Install a waste water pipe towards the drain.

5.4.2 Backwash water discharge with hose connection

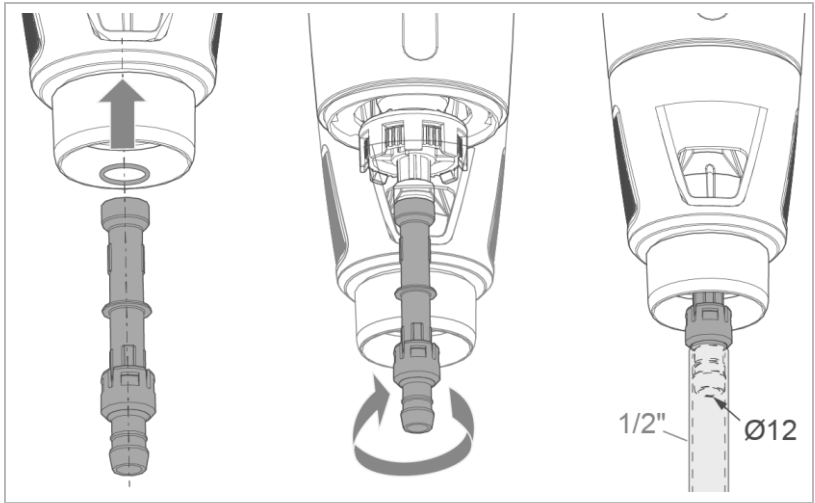

1. Mount the hose adapter on the filter.



The hose is not included in the scope of supply.

The hose length must not exceed 4 metres.

Longer hoses can lead to pressure loss and impair backwash.

NOTE

Stagnated water can remain in the hose due to insufficient slope.

- Bacterial growth in the filter
- ▶ Lay the hose with a downward slope.
- ▶ After backwashing, check that the water drains completely.
- ▶ If the water does not drain completely, remove the hose after backwashing.

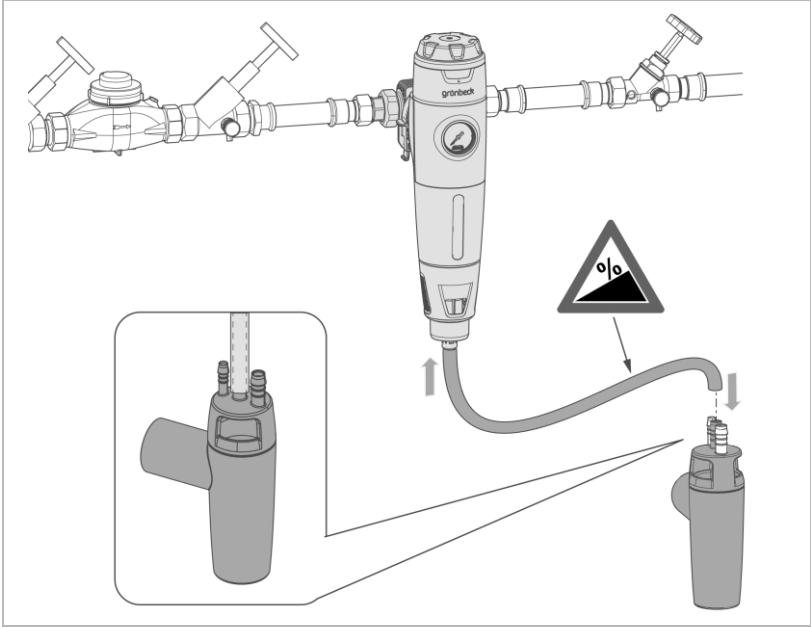

2. Connect an on-site hose to the hose adapter and to the installed drain connection.

Alternative discharge of the backwash water

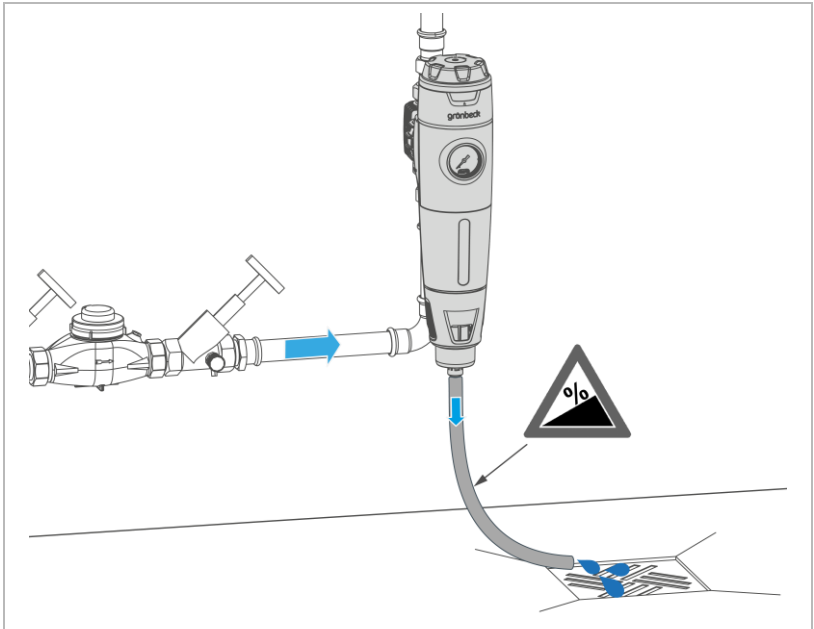

1. Connect an on-site hose to the hose adapter.
 2. Lay the hose to the discharge point (e.g. bucket, drain or floor outlet).
- ▶ Make sure that there is a free outlet for the backwash water at the discharge point.



6 Commissioning



The initial start-up of the product must be carried out by technical service personnel only.

6.1 Checking the product

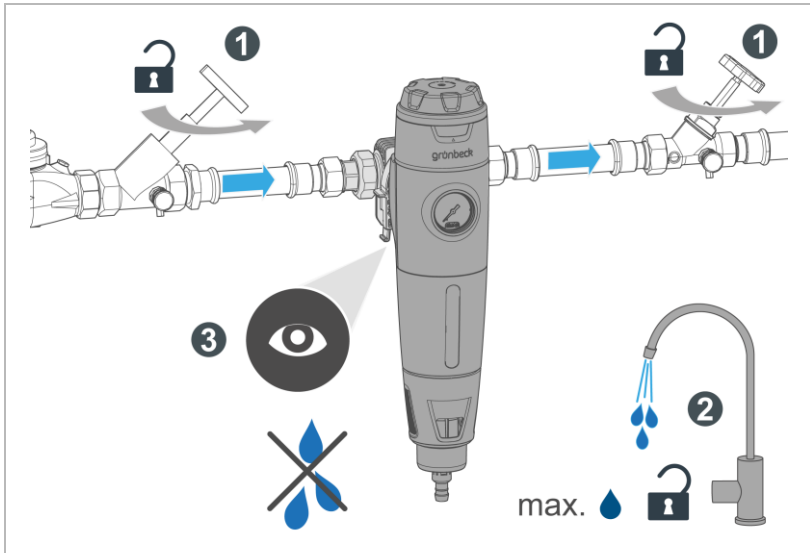

1. Open the shut-off valves.
2. Open the nearest water withdrawal point downstream of the filter as far as it will go.
 - » The filter is vented.
3. Check the filter for leaks.
4. Enter the initial start-up in the operation log.

6.2 Setting the month display



Via Grünbeck's myProduct app, you will receive a message about the timely backwash of the filter (refer to chapter 7.1).

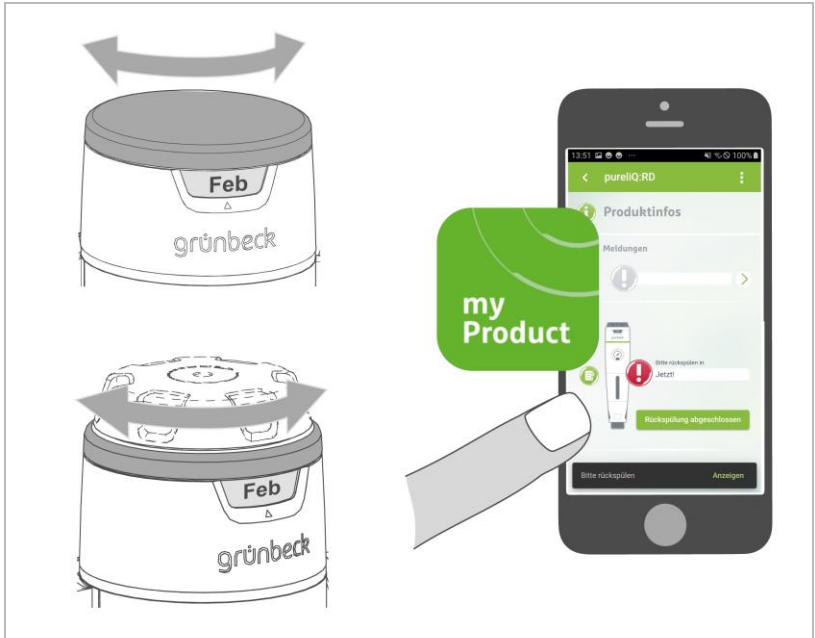

- Set the maintenance ring to the month of the next maintenance (alternatively, to the month of the next backwash – every six months at the latest).

6.3 Setting the pressure reducer (pureliQ:RDX)

The pressure reducer is factory-set to 4 bar.

You can change this value as follows:

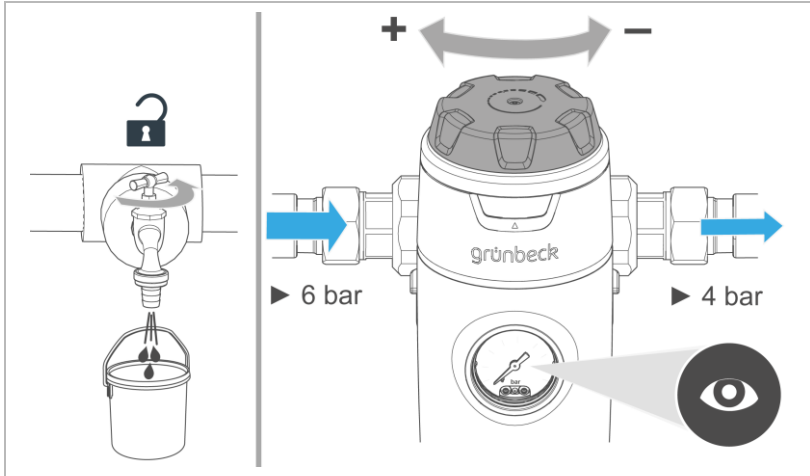

1. Set the desired downstream pressure on the pressure reducer handwheel
(turn anticlockwise = pressure increase, turn clockwise = pressure reduction).
2. Open and close a water withdrawal point.
 - » The outlet pressure adjusts itself.
3. Read the actual outlet pressure on the pressure gauge.
4. Repeat steps 1. – 3. until the desired pressure is reached.
 - » The desired outlet pressure is set.



The outlet pressure is set according to DIN EN 806-2.

- ▶ Comply with the max. admissible operating pressure.

6.4 Handing over the product to the owner/operating company

- ▶ Explain how the product works to the owner/operator/operating company.
- ▶ Use the manual to brief the owner/operator/operating company and answer their questions.
- ▶ Inform the owner/operator/operating company about the need for inspections and maintenance.
- ▶ Hand over all documents to the owner/operator/operating company for safekeeping.

6.4.1 Disposal of packaging

- ▶ Dispose of packaging material as soon as it is no longer needed (refer to chapter 11.2).

6.4.2 Storage of accessories

- ▶ Keep the accessories supplied for the product in a safe place.

7 Operation/handling

The product is operated automatically and does not require any manual operation.



CAUTION

Unlock the cliQlock module system under pressure

- Bumping, hitting through filter
- ▶ Shut off the water supply before operating the cliQlock module system.
- ▶ Ensure that the cliQlock module system is depressurised.
- ▶ Inspect the filter at regular intervals (refer to chapter 8.3).
- ▶ Carry out a backwash regularly (refer to chapter 8.4.1.1).
- ▶ Flush the filter after a temporary shutdown (refer to chapter 10.1).

7.1 Installing Grünbeck's myProduct app



You can register your product in the myProduct app. That way, you will receive a reminder to replace the filter element as well as additional information on your product.

- ▶ Download Grünbeck's myProduct app and install it on your mobile device.

8 Maintenance and repair

Maintenance and repair includes the cleaning, inspection and maintenance of the product.



The responsibility for inspection and maintenance is subject to local and national requirements. The owner/operator/operating company is responsible for compliance with the prescribed maintenance and repair work.



By concluding a maintenance contract you ensure that all maintenance work is performed on time.

- ▶ Only use genuine spare and wearing parts from Grünbeck.

8.1 Cleaning

NOTE

Do not clean the product with cleaning agents containing alcohol/solvents.

- These substances damage the plastic components.
- Varnished surfaces are affected.
- ▶ Use a mild/pH-neutral soap solution.
- ▶ Only clean the outside of the product.
- ▶ Do not use any strong or abrasive cleaning agents.
- ▶ Wipe the surfaces with a damp cloth.

8.2 Intervals



Regular work is necessary in order to ensure proper functioning of the product in the long term. DIN EN 806-5 recommends regular maintenance to ensure trouble-free and hygienic operation of the product.

- ▶ As owner/operator/operating company determine which components must be inspected and maintained at which intervals (load-dependent). These intervals are subject to the actual conditions, e.g.: Water condition, degree of impurities, environmental influences, consumption, etc.

The following interval table shows the minimum intervals for the activities to be performed.

Activity	Interval	Tasks
Inspection	2 months	<ul style="list-style-type: none"> • Visually check for function and leaks • Read the pressure (for pureliQ:RDX)
Maintenance	6 months	<ul style="list-style-type: none"> • Backwash • Check condition and leak tightness • Adjust the maintenance ring
	annually as needed	<ul style="list-style-type: none"> • Backwash • Check O-rings/seals for wear • Check that the filter and the cliQlock basic module are firmly seated
Repair	5 years	<ul style="list-style-type: none"> • Recommendation: Replace filter element, seals, backwash valve, spring assembly
	10 years	<ul style="list-style-type: none"> • Recommendation: Replace the filter cylinder

8.3 Inspection

You as owner/operator/operating company can carry out the regular inspections yourself.

- ▶ Conduct an inspection at least every 2 months.

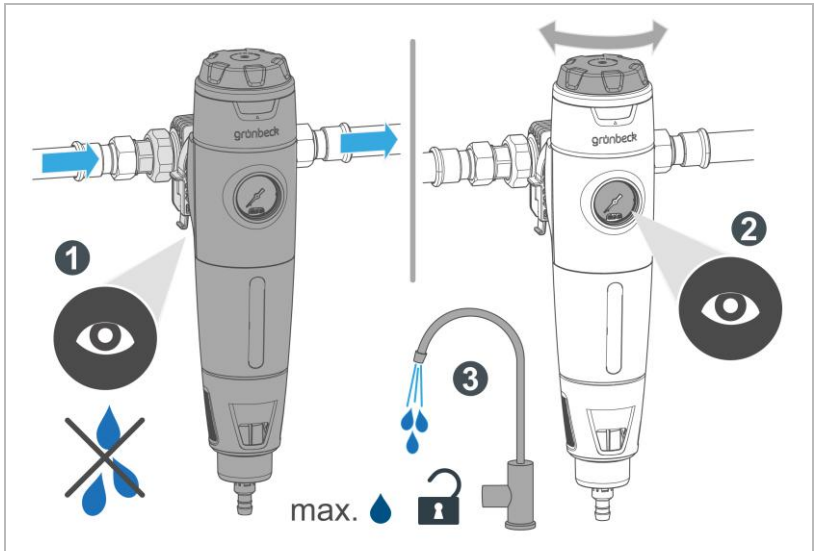

1. Check the installation for leaks and function.
 2. Read the static pressure (zero flow) of pureliQ:RDX.
 3. Fully open a water withdrawal point (generate max. flow) and read the flow pressure.
- ▶ Carry out a backwash in case of increasing contamination of the filter element and/or decreasing water pressure in the pipe network.

8.4 Maintenance



WARNING

Irregular backwash of the filter

- Risk of infection due to contamination
- ▶ Comply with the intervals for inspection and backwash of the filter.

8.4.1 Semi-annual maintenance

8.4.1.1 Filter backwash



During the backwash process, filtered pure water is still available.

We recommend repeating the backwash process 3 times.

Backwash via hose connection

NOTE

Stagnated water can remain in the hose due to insufficient slope.

- Bacterial growth in the filter
- ▶ After backwashing, check that the water drains completely.
- ▶ If the water does not drain completely, remove the hose after backwashing.

- ▶ For an installation without a duct connection or hose connection, place a 10 l bucket under the filter.

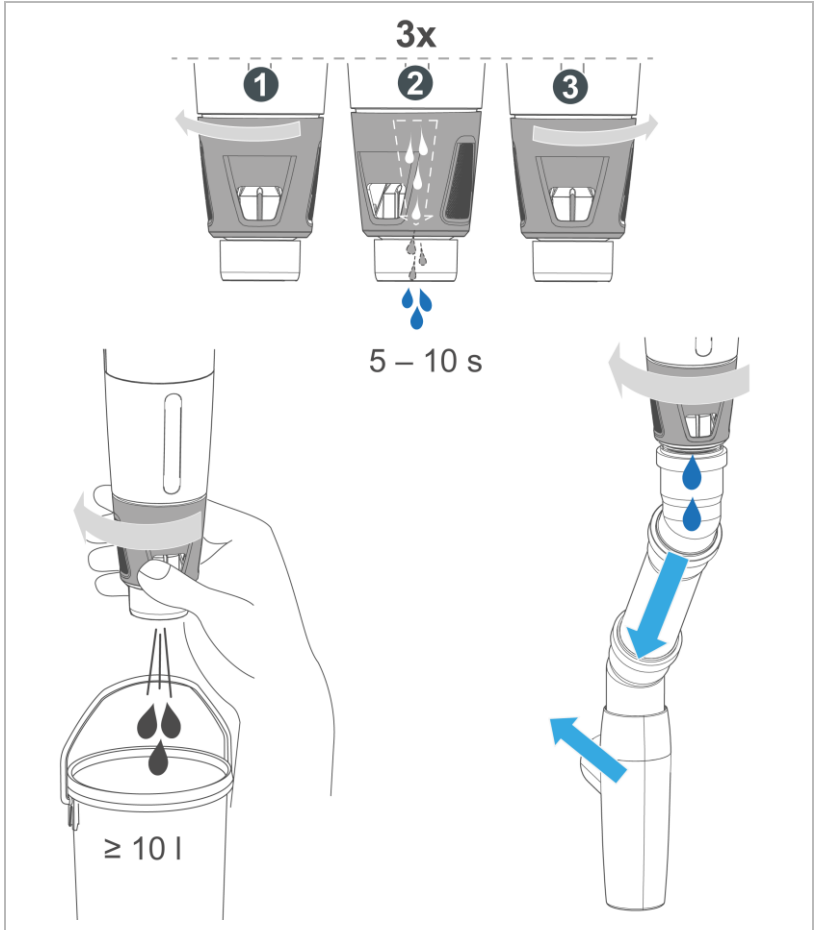

1. Turn the backwash handwheel to the left in the direction of the arrow as far as it will go.
2. Hold the backwash handwheel in this position for 5 – 10 seconds.
3. Turn the backwash handwheel to the right back to its initial position.

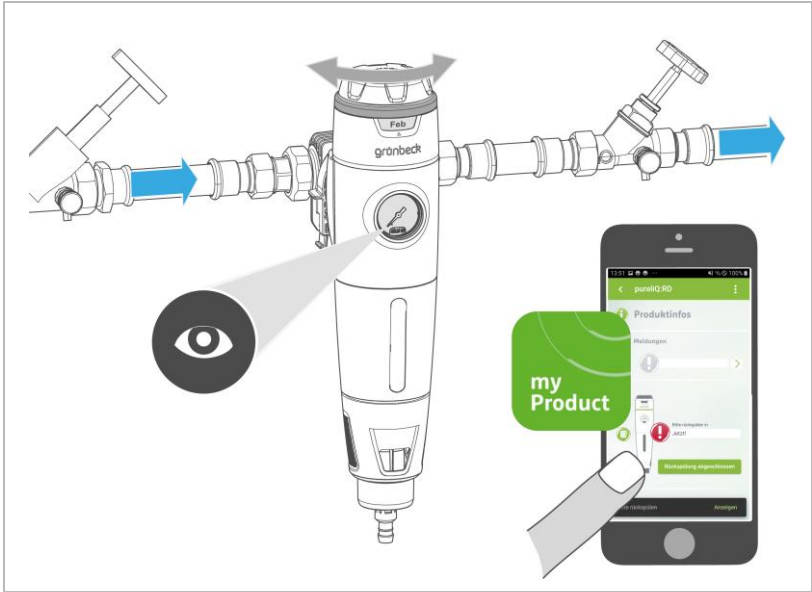

4. Check the water pressure of the pureliQ:RDX:
 - a Fully open a water withdrawal point and read the flow pressure on the pressure gauge.
 - b Close the water withdrawal point and read the static pressure (zero flow) on the pressure gauge.
 - c Adjust the holding pressure if required.
5. Set the date for the next maintenance (refer to chapter 6.2).
6. Confirm the backwash in the Grünbeck myProduct app, if registered.

8.4.2 Annual maintenance



The following work must be carried out by a qualified specialist only.

If a leak or malfunction is detected, conduct a wear test in addition to the semi-annual maintenance:

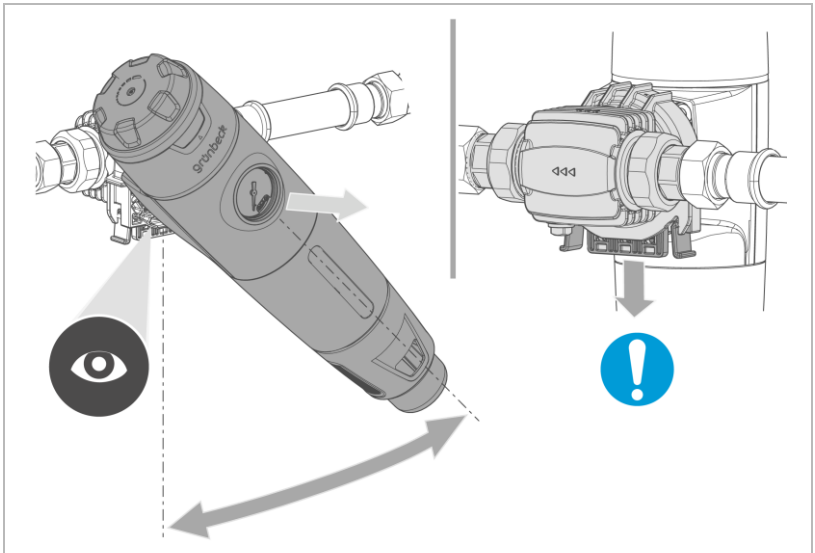

1. Detach the drain connection from the filter.
2. Check the tight fit of the filter on the cliQlock basic module.
 - a Pull on the filter plug and swivel it.
 - » The filter must not come loose from the cliQlock basic module.
 - » The connection point must not leak.
3. Pull on the cliQlock clip without unlocking it.
 - » The cliQlock clip must not come loose.

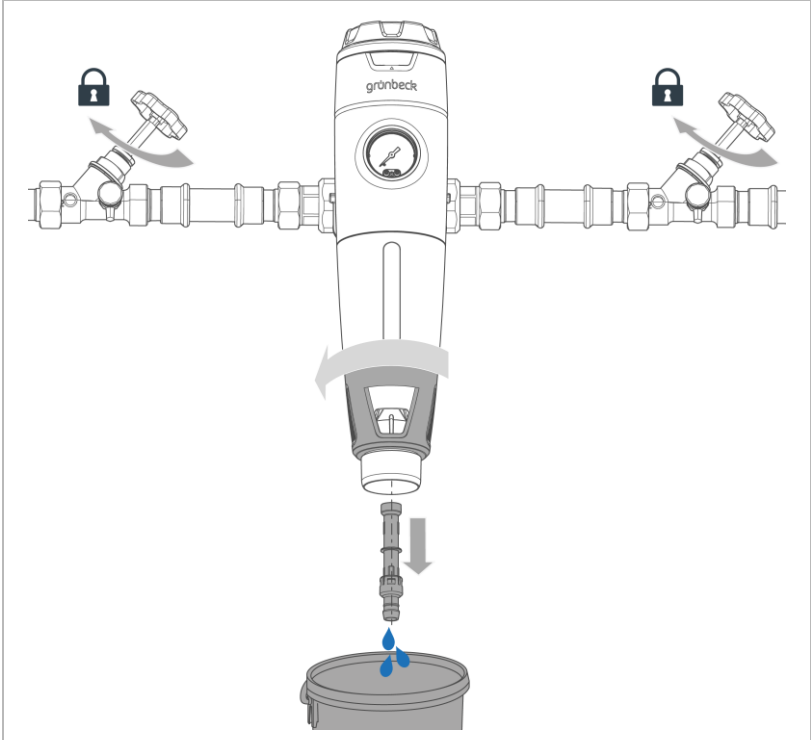

4. Close the shut-off valves at the inlet and outlet.
5. Carry out a backwash to relieve the water pressure in the filter and in the water pipe.
6. Dismantle the drain connection or the hose adapter (if fitted).

- If the connection point is leaking, proceed as follows.

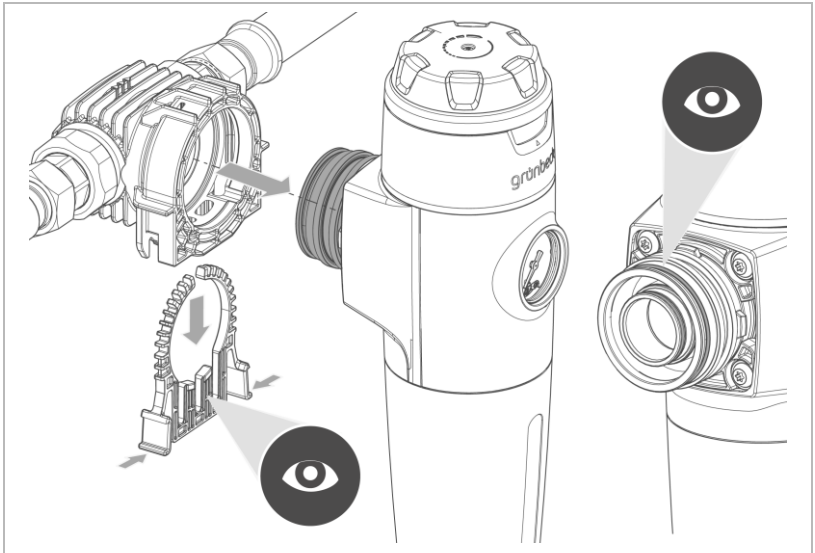

7. Detach the filter from the cliQlock basic module.
 - a Pull out the cliQlock clip.
 - b Carefully pull the filter out.
8. Check the O-rings on the plug-in coupling for wear.
9. Check the cliQlock clip and the cliQlock basic module for cracks and warping.

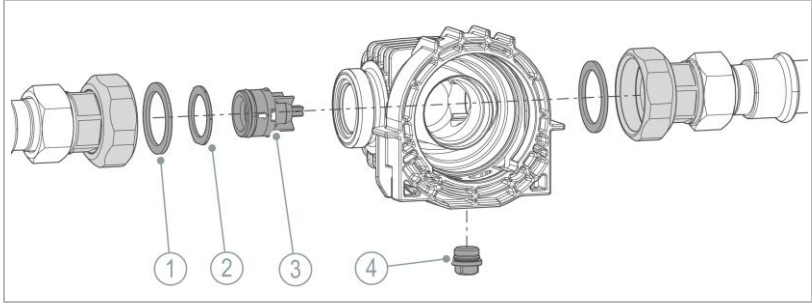

Designation	Designation
1 Flat seals for the water meter screw connection	3 Non-return valve
2 Seal of the non-return valve	4 Blind plug with O-ring for dosing valve

10. If necessary, dismantle the cliQlock basic module and check the seals on the water meter screw connections for wear.

11. Check the non-return valve for wear.

12. Check the blind plug with O-ring for wear.

13. Replace worn components.

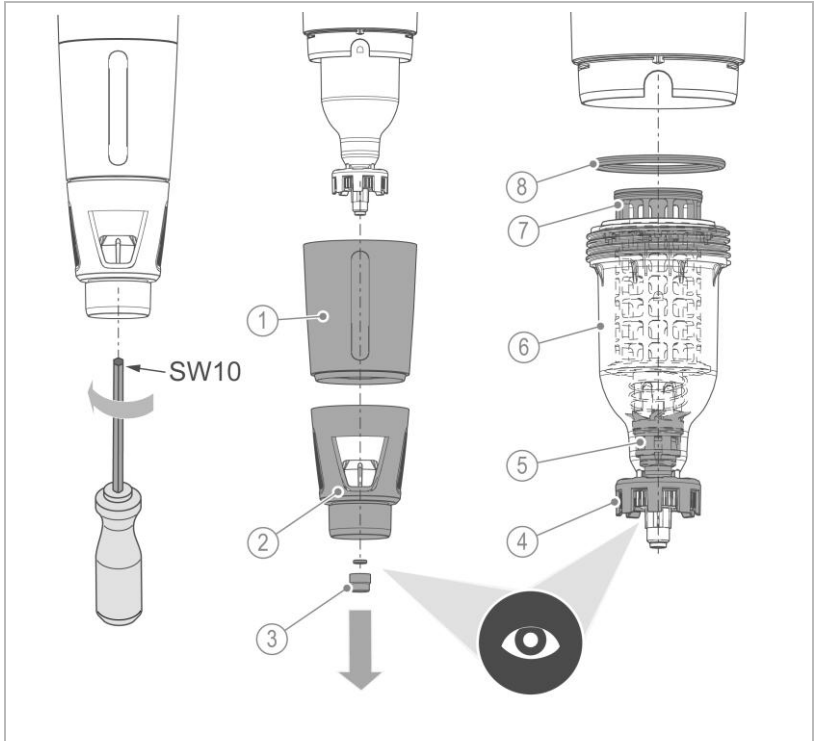

Designation

- 1 Filter bell cover
- 2 Backwash handwheel
- 3 Fastening nut incl. seal
- 4 Spring assembly

Designation

- 5 Backwash valve incl. seal
- 6 Filter cylinder
- 7 Filter element
- 8 O-ring filter cylinder

- 14.** Dismantle the backwash handwheel with the filter cylinder cover.
- 15.** Unscrew the filter cylinder.
- 16.** Check the O-rings and flat seals for wear and tear.
- 17.** Check the spring assembly and backwash valve for smooth running and damage.
- 18.** Check the filter element for damage and dirt deposits.
- 19.** Replace worn components (refer to chapter 8.7).
- 20.** Mount the filter and put the installation into operation (refer to chapter 6).

8.5 Spare parts

For an overview of the spare parts, refer to our spare parts catalogue at www.gruenbeck.com. You can obtain the spare parts from your local Grünbeck representative.

8.6 Wearing parts



Wearing parts are only allowed to be replaced by a qualified specialist.

Wearing parts are listed below:

- Seals (O-rings)
(Seal set for filter cylinder and support mesh, order no. 101625e)
 - Filter element
 - Backwash valve
- ▶ Have the seals replaced in the event of leaks, damage or deformations.

8.6.1 Recommended replacement interval

- 5 years for filter element incl. seal, O-ring filter cylinder, backwash valve incl. seals, spring assembly
 - 10 years for filter cylinder
- ▶ Have defective or worn components replaced (refer to chapter 8.7).

8.7 Service Kits

8.7.1 Service kits for pureliQ:RX

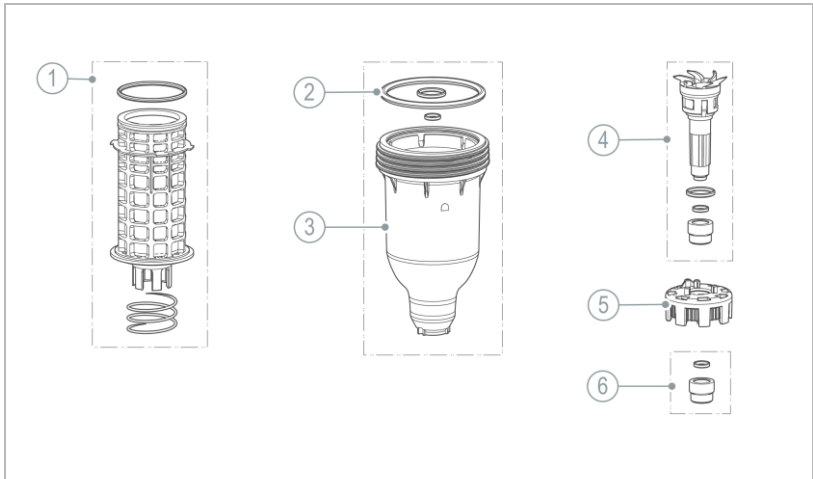

Designation	
1	Filter element
2	O-ring filter cylinder
3	Filter cylinder

Designation	
4	Backwash valve incl. seals
5	Spring assembly
6	Fastening nut incl. seal

Designation	consisting of	Order no.
Service kit I	<ul style="list-style-type: none"> Filter element 100 µm incl. seal O-ring filter cylinder Backwash valve incl. seals Spring assembly 	101 676e
Service kit II	<ul style="list-style-type: none"> Service kit I Filter cylinder 	101 677e

8.7.2 Service kits for pureliQ:RDX

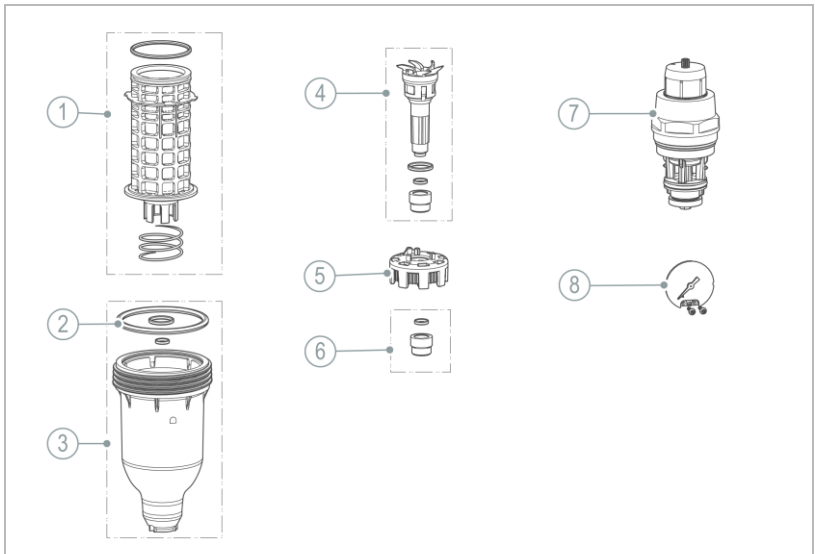

Designation

- | | |
|---|----------------------------|
| 1 | Filter element |
| 2 | O-ring filter cylinder |
| 3 | Filter cylinder |
| 4 | Backwash valve incl. seals |

Designation

- | | |
|---|--------------------------|
| 5 | Spring assembly |
| 6 | Fastening nut incl. seal |
| 7 | Pressure reducer |
| 8 | Pressure gauge |

Designation	Consisting of	Order no.
Service kit III	<ul style="list-style-type: none"> • Service kit I • Pressure reducer • Pressure gauge 	101 678e
Service kit IV	<ul style="list-style-type: none"> • Service kit III • Filter cylinder 	101 679e

Tools required	Order no.
Strap wrench (to remove the filter cylinder)	105 805
Pipe socket wrench (for pressure reducer cartridge)	104 805
Allen key 10 (for fastening nut)	
TORX T8 (pressure gauge)	
TORX T10 (pressure reducer adjusting cap)	

9 Fault



WARNING

Contaminated drinking water due to stagnation

- Infection
- ▶ Have faults remedied immediately.

9.1 Observations

Observation	Explanation	Remedy
Water pressure at the withdrawal point too low (pressure loss too high)	The shut-off valves are not fully open	▶ Fully open the shut-off valves
	The filter element is dirty	▶ Carry out backwash
	The pressure reducer is not set correctly or is defective	▶ Have the pressure reducer checked, adjusted or replaced by the technical service.
Taste of the treated water negatively affected	Excessive filter down-time	▶ Withdraw water for several minutes
		▶ Carry out backwash
Solids contained in the filtered water	Excessively high flow through the filter	▶ Check filter element for damage or leaks
	Filter element damaged or not installed correctly	▶ Have the filter element replaced by technical service

Observation	Explanation	Remedy
Water loss in the system (leakage)	Faulty joint	<ul style="list-style-type: none">▶ Check O-rings and seals for deformations or wear and tear▶ Check filter head for damage▶ Check cliQlock basic module checked for damage▶ Have leaky components replaced by a qualified specialist



If a fault cannot be rectified, further measures can be taken by the technical service.

- ▶ Contact technical service (for contact details, refer to the inside cover sheet).

10 Decommissioning

It is not necessary to take your product out of operation.



In case of longer absences, e.g. holidays, precautionary hygiene measures according to VDI 3810-2 and VDI 6023-2 must be taken in order to maintain drinking water hygiene after downtimes.

10.1 Temporary standstill

- ▶ Perform the activities below if the drinking water system has not been used for a longer period of time:

After a downtime of ≤ 4 weeks

- ▶ Open a water withdrawal point and completely flush the filter and the pipes.

After a downtime of > 4 weeks

1. Carry out a backwash (refer to chapter 8.4.1.1).
2. Open a water withdrawal point and completely flush the filter and the pipes.

11 Dismantling and disposal

11.1 Dismantling



The work described herein represents an intervention into your drinking water system.

- ▶ Have this work performed by qualified specialists only.
1. Close the shut-off valves upstream from the filter.
 2. Open a water withdrawal point and wait for a few seconds.
 - » The pressure in the product and the pipe network is being relieved.
 3. Close the water withdrawal point.
 4. Close the shut-off valve downstream of the filter.
 5. Carry out a backwash.

11.1.1 Removing the filter from the cliQlock basic module



When removing the filter, the plug-in coupling can get stuck in the cliQlock basic module.

- ▶ Use hygiene gloves when carrying out this work.
- ▶ Observe the following when removing the filter:

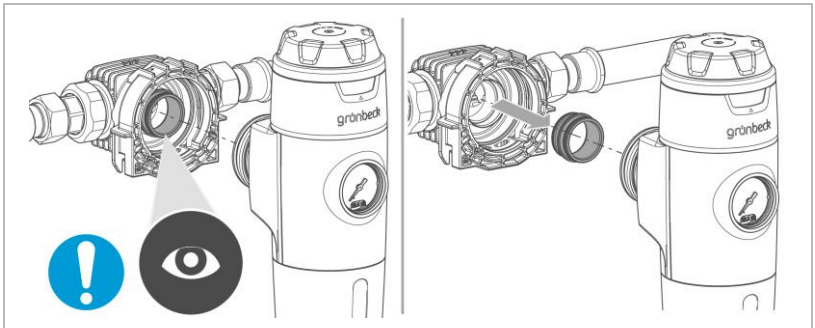

1. Pull the plug-in coupling out of the cliQlock basic module by hand - do not use any tools.

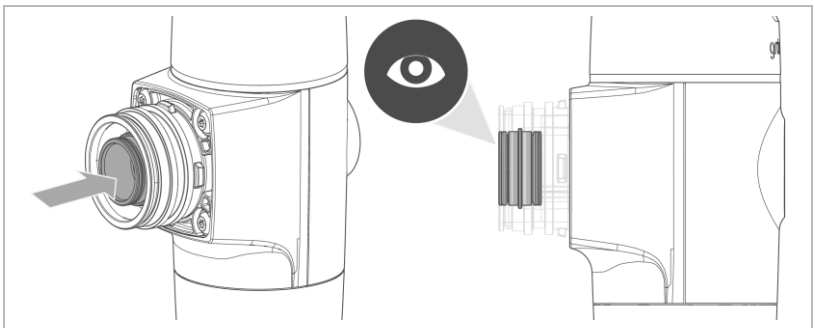

2. Insert the plug-in coupling into the filter connection as far as it will go.

11.2 Disposal

- ▶ Comply with the applicable national regulations.

Packaging

- ▶ Dispose of the packaging in an environmentally sound manner.

NOTE

Risk to the environment due to incorrect disposal

- Packaging materials are valuable raw materials and can be reused in many cases.
- Incorrect disposal can cause environmental hazards.
- ▶ Dispose of packaging material in an environmentally sound manner.
- ▶ Comply with locally applicable disposal regulations.
- ▶ If necessary, commission a specialist company with the disposal.

Product



If this symbol (crossed-out wheellie bin) is on the product, this product or its electrical and electronic components, must not be disposed of as household waste.

- ▶ Use the available collection points for the disposal of your product.
- ▶ If your product contains batteries or rechargeable batteries, dispose of them separately from your product.



For more information on take-back and disposal, go to www.gruenbeck.com.

Publisher's information

Technical documentation

If you have any questions or suggestions regarding this operation manual, please contact the Technical Documentation Department at Grünbeck

Email: dokumentation@gruenbeck.de

Grünbeck AG
Josef-Grünbeck-Str. 1
89420 Hoehstaedt
Germany

 +49 9074 41-0

 +49 9074 41-100

info@gruenbeck.com
www.gruenbeck.com



For more Information go to
www.gruenbeck.com